



CERTIFIKAT o EU-pregledu tipa EU-Type Examination Certificate

št. /No. **SI 20-11-010 MID** revizija št. / Revision No.: **6**

certifikat izdal
issued by

Urad RS za meroslovje
Metrology Institute of the Republic of Slovenia (MIRS)

Priglašen organ št.
Notified body No.

1376

certifikacijski organ ni akreditiran za namen priglasitve
the certification body is not accredited for the purpose of notification

na podlagi
in accordance with

1. odstavka 9. člena Zakona o meroslovju (Uradni list RS, št. 26/05 – uradno prečiščeno besedilo) in 14. člena Pravilnika o merilnih instrumentih (Uradni list RS, št. 19/16 in 98/23), ki povzema vsebino Direktive 2014/32/EU Evropskega parlamenta in Sveta z dne 26. februarja 2014 o harmonizaciji zakonodaj držav članic v zvezi z dostopnostjo merilnih instrumentov na trgu (prenovitev)
Metrology Act (OJ of RS, No. 26/05), Article 9, Paragraph 1, and Rules on measuring instruments (OJ of RS, No. 19/16 and 98/23), Article 14, which implements Directive 2014/32/EU of the European Parliament and of the Council of 26 February 2014 on the harmonization of the laws of the Member States relating to the making available on the market of measuring instruments (recast)

izdano proizvajalcu
issued to manufacturer

ISKRA, d. o. o.
Stegne 21, SI – 1000 Ljubljana, Slovenija

za
in respect of

Trifazni in enofazni elektronski števec delovne električne energije
Three-phase and single-phase electronic active energy meter

tip
type

WM3M4, WM3M4C

bistvene zahteve
essential requirements

Pravilnik o merilnih instrumentih, priloga 1, Bistvene zahteve, in Priloga 5 (MI-003), Števci delovne električne energije
Rules on measuring instruments, which implements Measuring Instruments Directive, Annex 1 Essential requirements, and Annex 5 (MI-003) Active electrical energy meters

veljavnost do
valid until

4. 6. 2030

Glavne značilnosti, pogoji in omejitve so podani v prilogi, ki je sestavni del tega certifikata.
The principal characteristics, approval conditions are set out in the Annex hereto, which forms part of the this certificate.

Št. strani priloge: 10
No. of Annex pages:

Ta revizija certifikata v celoti zamenjuje prejšnjo verzijo certifikata.
This revision of the certificate completely replaces previous version.

Št. dokumenta: 6413-10/2024/10
Ljubljana, 19. 9. 2024

Postopek vodil:

Grega Kovačič
sekretar

Dr. Samo Kopač
direktor

1. Instrument

The three-phase energy meters WM3M4 and WM3M4C are intended for energy measurements in a three-phase or single-phase electrical charger stations. The meters measure energy directly in 4-wire or single-phase two wire network according to the principle of fast sampling of voltage and current signals. A built-in microprocessor calculates active energy, active/reactive/apparent power, current, voltage, THD, frequency, power factor, power angle and frequency (for each phase and total sum) from the measured signals. Microprocessor also controls LCD, LED, IR and RS 485 communication. The meters can measure in both directions.

WM3M4C/WM3M4 meter can detect and log events relevant for charging via RS485 communication. Thus the meter can produce relevant digital signature for charging event. The WM3M4C energy meter features high temperature operation and digital signing for a charging event, whereas WM3M4 features only high temperature operation.

2. Design of the instrument

2.1 Construction

1. RS485 terminals
2. Current terminals – to load
3. LCD display
4. IR COMM PORT – on side
5. Public key as QR code (valid only for WM3M4C)
6. LED indicator (1000 imp/kWh)
7. Current terminal – source (max 40 A)

LCD

Number of digits: 8 (6+2)
Height of digits: 6.52 mm

LED

Color: red
Pulse rate: 1000 imp/kWh
LED on: no load indication

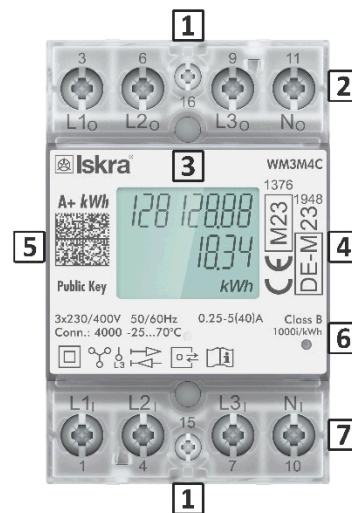

Figure 1:WM3M4C Meter parts

2.2 Sensor

For a current input the shunt resistor is applied. Voltage is measured by the resistor voltage divider.

2.3 Measurement value processing

2.3.1 Operating principle

The meter is connected via terminal block to the network. The metering elements consist of a current sensor (shunt) and a voltage sensor, which signals are fed to the metering integrated circuit. The microcontroller acquires signals from the metering element, processes them and calculates values of measured energy. Results are stored in registers and can be seen on the LCD.

When three phases are implied import/export is defined on the basis of sum of phase powers $P1 + P2 + P3$. If the sum of phase powers is positive, import register counts, if the sum of phase powers is negative, export register counts.

2.3.2 Hardware

WM3M4C/WM3M4 energy meter is supplied from phase power supply units using capacitor based power supply. Current and voltage is measured in measurement system. A shunt resistor is used for current sensor. Measuring mains voltage is applied with a resistor voltage divider.

Meter can be used also for single-phase measurement in two wire network. In this case it shall be connected only in phase L3.

The method for sampling voltage and current is based on A/D conversion. The microprocessor unit is used for signal and measurement processing.

Basic meter data, parameters and calibration constants are stored in EEPROM.

WM3M4C/WM3M4 energy meter does not have any adjustable elements (potentiometers), which assures a better long-term stability.

LCD is driven directly from microprocessor and is used for displaying various parameters dedicated to charging process(cumulative, imported and exported active energy register, energy consumption of actual charging event, charging duration, charging power, export active energy counter, transaction number, date and time)and some identification parameters (serial number, SW version or custom string). Imported active energy register is displayed permanently in the first row, whereas the data for the second row can be set with the parameter via MiQen 2.1.

2.3.3 Software

The software was developed for the meter which is designed based on the microcontroller STM32L073. The software is identified by software version and software checksum of the main processor and check sum of the software of phase measuring modules. The software version and both check sums are displayed immediately after full display test at the start-up. The software version and software checksum can also be read by use of MiQen2.1 software during operation of the meter through IR port or RS485 communication. Firmware (FW) identification window can also be displayed on the LCD for a certain period of time using MODBUS command through RS 485 communication.

MID key prevents the upgrade of software and modification of parameters related to energy measurement. Unlocking the key is possible only after breaking the seal and opening the meter. In case the meter is not locked the ERR 0004 is shown on the LCD.

FW identification window:

- 1 CRC of main FW MCU
- 2 CRC of measuring modules FW
- 3 Main FW version



Figure 2: WM3M4C/WM3M4 example of FW identification

2.4 Indication of the measurement results

Energy meters have LCD display with following layout.

- 1 Total kWh - reception
- 2 User settable line
- 3 4 digit label
- 4 kWVA display
- 5 kWh display

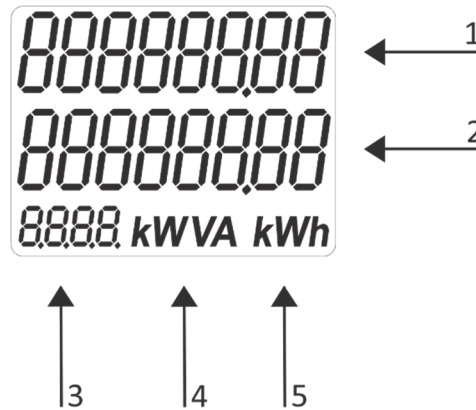

Figure 3: LCD Layout

LCD Display has 2 rows with 8 digits each and 4 digit label. Display scrolls automatically. Displayed quantities and scroll time can be set via communication by MiQen software. Top row always displays imported active energy consumption.

2.5 Permissible functions and devices

Measured quantities subjected to approval:

- Energy measurements (active),
- Digitally signed transaction data (energy register value at start and end of charging with time stamps and digital signature for data authentication).

2.6 Technical documentation

The valid technical documentation is kept by MIRS in the reference file 6413-5/2018, 6413-4/2020, 6413-4/2021, 6413-1/2023, 6413-5/2024 and 6413-10/2024.

2.7 Integrated equipment and functions not subjected to approval

- Reactive and apparant energy measurement
- Active, reactive and apparent power measurement
- Voltage measurement
- THD measurement in voltage and current
- Current measurement
- Power factor measurement
- Frequency measurement
- Reference frequency 60 Hz

3. Technical data

| | |
|-------------------------------------|--|
| Reference voltage: | 3 x 230 V/400 V or 1 x 230 V on phase L3 |
| Reference current/Max. current: | 5 A/ 40 A |
| Reference frequency: | 50 Hz and 60 Hz |
| Accuracy class: | B |
| Starting current: | 20 mA |
| Minimum current: | 250 mA |
| Transitional current | 0,5 A |
| Meter constant: | 1000 imp/kWh |
| Dust/water protection | IP50* |
| Protective class of insulation: | II |
| Environment / influence quantities: | |
| Climatic environment: | From -25 °C to 70 °C, (non-condensing humidity, closed |

| | |
|------------------------------|-----------|
| | location) |
| Mechanic environment: | M1 |
| Electromagnetic environment: | E2 |
| Minimum measuring time | 10 s |

* For IP51 it should be installed in appropriate cabinet.

4. Interfaces and compatibility conditions

4.1 Interfaces

The meter is equipped with the following interface modules:

- IR optical communication with MODBUS RTU protocol,
- RS485 serial communication with the MODBUS RTU protocol.

5. Requirements on production, putting into use and consistent utilization

5.1 Requirements on production

Electronic three-phase and single-phase (L3) electricity meters must be constructed in accordance with the requirements of the section 2 of this certificate.

For built-in sensor the requirements of section 2.2 of this certificate shall be fulfilled.

5.2 Requirements on putting into use

Before the first application, the following steps have to be performed:

- Visually check the compliance with the approved type
- Check the operation of the measuring instrument without load
- Check starting current
- Check correct operation of a pulse transmitter in comparison with energy registers
- Energy measurement accuracy - maximum permissible error (MPE)

For the confirmation of the compliance of an individual meter during the verification procedure, putting into operation or inspection of compliance with the maximum permissible errors (MPE), Table 2, Annex V (MI003) "Active electrical energy meters" of Directive 2014/32/EU of the European Parliament and Council, a measurement error as a combined error of measuring accuracy at reference conditions and contributions of influence quantities is defined. The error at reference conditions is defined, in testing procedures for an individual meter. In continuation a factor of contributions of influence quantities for the temperature range from +5 °C to +30 °C, voltage and frequency are stated (table 1 and 2). The factor is considered when defining a common measurement error for a certain meter type.

A sum of squares of individual quantities is stated, and calculated by formula in the tables below:

$$\sqrt{\delta_T^2(T, I, \cos \varphi) + \delta_U^2(U, I, \cos \varphi) + \delta_f^2(f, I, \cos \varphi)}$$

Table 1: Three phase connection

| I | phase | PF | Min. meas. time [s] | $(\delta_T^2(T, I, \cos \varphi) + \delta_U^2(U, I, \cos \varphi) + \delta_f^2(f, I, \cos \varphi))^{1/2}$ [%] |
|----------------------------------|--------|------------|---------------------|--|
| Active energy - reception | | | | |
| I_{tr} | L1L2L3 | 1 | 10 | 0,18 |
| $10I_{tr}$ | L1L2L3 | 1(0°) | 10 | 0,15 |
| I_{max} | L1L2L3 | 1(0°) | 10 | 0,12 |
| I_{tr} | L1L2L3 | 1(0°) | 10 | 0,12 |
| $10I_{tr}$ | L1L2L3 | 0.5L (60°) | 10 | 0,12 |

| I | phase | PF | Min. meas. time [s] | $(\delta_i^2(T, I, \cos\varphi) + \delta_u^2(U, I, \cos\varphi) + \delta_f^2(f, I, \cos\varphi))^{1/2}$ [%] |
|-----------------------------------|--------|-------------------|---------------------|---|
| I _{max} | L1L2L3 | 0.5L (60°) | 10 | 0,06 |
| I _{tr} | L1L2L3 | 0.5L (60°) | 10 | 0,06 |
| 10I _{tr} | L1L2L3 | 0.8C (323,13°) | 10 | 0,09 |
| I _{max} | L1L2L3 | 0.8C (323,13°) | 10 | 0,09 |
| I _{tr} | L1L2L3 | 0.8C (323,13°) | 10 | 0,07 |
| 10I _{tr} | L1 | 1(0°) | 10 | 0,05 |
| I _{max} | L1 | 1(0°) | 10 | 0,07 |
| I _{tr} | L1 | 1(0°) | 10 | 0,07 |
| 10I _{tr} | L2 | 1(0°) | 10 | 0,10 |
| I _{max} | L2 | 1(0°) | 10 | 0,16 |
| I _{tr} | L2 | 1(0°) | 10 | 0,11 |
| 10I _{tr} | L3 | 1(0°) | 10 | 0,08 |
| I _{max} | L3 | 1(0°) | 10 | 0,05 |
| I _{tr} | L3 | 1(0°) | 10 | 0,05 |
| 10I _{tr} | L1 | 0.5L (60°) | 10 | 0,07 |
| I _{max} | L1 | 0.5L (60°) | 10 | 0,12 |
| I _{tr} | L1 | 0.5L (60°) | 10 | 0,05 |
| 10I _{tr} | L2 | 0.5L (60°) | 10 | 0,10 |
| I _{max} | L2 | 0.5L (60°) | 10 | 0,11 |
| I _{tr} | L2 | 0.5L (60°) | 10 | 0,09 |
| 10I _{tr} | L3 | 0.5L (60°) | 10 | 0,08 |
| I _{max} | L3 | 0.5L (60°) | 10 | 0,10 |
| I _{tr} | L3 | 0.5L (60°) | 10 | 0,06 |
| Active energy - generation | | | | |
| I _{min} | L1L2L3 | 1 | 10 | 0,08 |
| I _{tr} | L1L2L3 | 1(180°) 3F | 10 | 0,08 |
| 10I _{tr} | L1L2L3 | 1(180°) 3F | 10 | 0,07 |
| I _{max} | L1L2L3 | 1(180°) 3F | 10 | 0,05 |
| I _{tr} | L1L2L3 | 0.5L (240°) 3F | 10 | 0,07 |
| 10I _{tr} | L1L2L3 | 0.5L (240°) 3F | 10 | 0,04 |
| I _{max} | L1L2L3 | 0.5L (240°) 3F | 10 | 0,05 |
| I _{tr} | L1L2L3 | 0.8C (143,13°) 3F | 10 | 0,08 |
| 10I _{tr} | L1L2L3 | 0.8C (143,13°) 3F | 10 | 0,08 |
| I _{max} | L1L2L3 | 0.8C (143,13°) 3F | 10 | 0,05 |
| I _{tr} | L1 | 1(180°) 1F | 10 | 0,09 |
| 10I _{tr} | L1 | 1(180°) 1F | 10 | 0,09 |
| I _{max} | L1 | 1(180°) 1F | 10 | 0,05 |
| I _{tr} | L2 | 1(180°) 1F | 10 | 0,13 |
| 10I _{tr} | L2 | 1(180°) 1F | 10 | 0,12 |
| I _{max} | L2 | 1(180°) 1F | 10 | 0,12 |
| I _{tr} | L3 | 1(180°) 1F | 10 | 0,08 |
| 10I _{tr} | L3 | 1(180°) 1F | 10 | 0,05 |
| I _{max} | L3 | 1(180°) 1F | 10 | 0,07 |
| I _{tr} | L1 | 0.5L (240°) 1F | 10 | 0,06 |
| 10I _{tr} | L1 | 0.5L (240°) 1F | 10 | 0,09 |
| I _{max} | L1 | 0.5L (240°) 1F | 10 | 0,04 |
| I _{tr} | L2 | 0.5L (240°) 1F | 10 | 0,11 |
| 10I _{tr} | L2 | 0.5L (240°) 1F | 10 | 0,12 |
| I _{max} | L2 | 0.5L (240°) 1F | 10 | 0,11 |

| I | phase | PF | Min. meas. time [s] | $(\delta_i^2(T, I, \cos\varphi) + \delta_u^2(U, I, \cos\varphi) + \delta_f^2(f, I, \cos\varphi))^{1/2}$ [%] |
|------------|-------|----------------|---------------------|---|
| I_{tr} | L3 | 0.5L (240°) 1F | 10 | 0,09 |
| $10I_{tr}$ | L3 | 0.5L (240°) 1F | 10 | 0,07 |
| I_{max} | L3 | 0.5L (240°) 1F | 10 | 0,06 |

Table 2: Single phase connection

| I | PF | Min. meas. time [s] | $(\delta_i^2(T, I, \cos\varphi) + \delta_u^2(U, I, \cos\varphi) + \delta_f^2(f, I, \cos\varphi))^{1/2}$ [%] |
|-----------------------------------|------|---------------------|---|
| Active energy - reception | | | |
| I_{min} | 1 | 10 | 0,09 |
| I_{tr} | 1 | 10 | 0,09 |
| I_{tr} | 0.5L | 10 | 0,05 |
| I_{tr} | 0.8C | 10 | 0,06 |
| I_b | 1 | 10 | 0,03 |
| I_b | 0.5L | 10 | 0,02 |
| I_b | 0.8C | 10 | 0,05 |
| I_{max} | 1 | 10 | 0,04 |
| I_{max} | 0.5L | 10 | 0,04 |
| I_{max} | 0.8C | 10 | 0,03 |
| Active energy - generation | | | |
| I_{min} | 1 | 10 | 0,09 |
| I_{tr} | 1 | 10 | 0,08 |
| I_{tr} | 0.5L | 10 | 0,06 |
| I_{tr} | 0.8C | 10 | 0,05 |
| I_b | 1 | 10 | 0,04 |
| I_b | 0.5L | 10 | 0,02 |
| I_b | 0.8C | 10 | 0,04 |
| I_{max} | 1 | 10 | 0,03 |
| I_{max} | 0.5L | 10 | 0,02 |
| I_{max} | 0.8C | 10 | 0,03 |

5.3 Requirement for consistent utilization

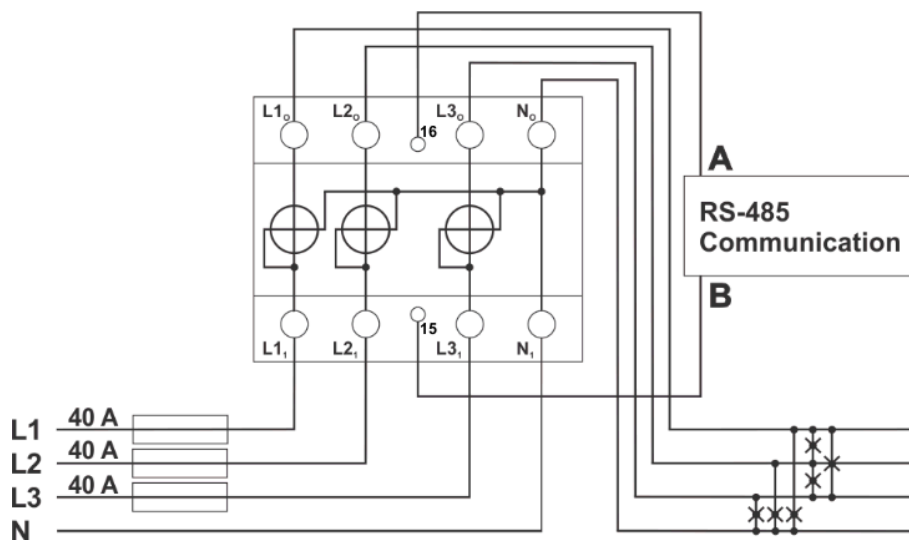

Figure 4: Three-phase connection diagram in four wire network.

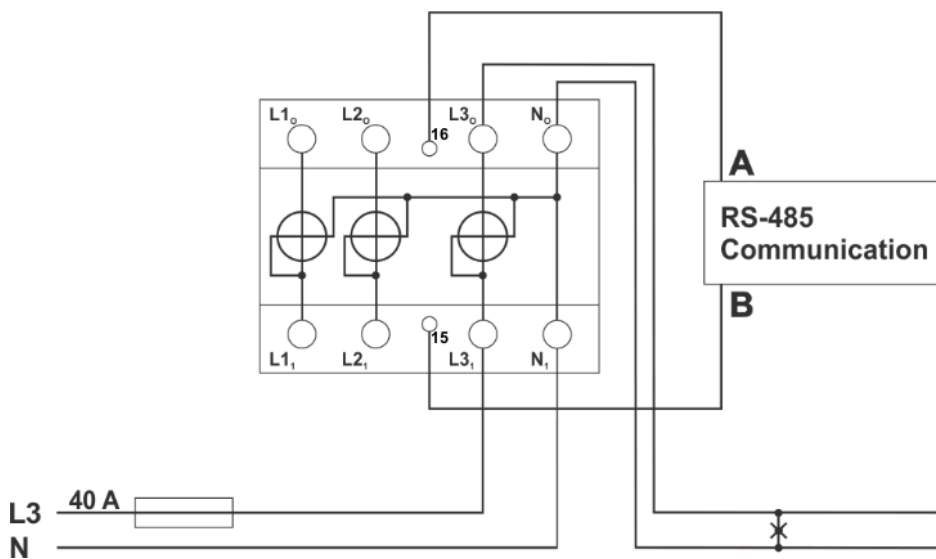

Figure 5: Single phase connection diagram in two wire network.

6. Surveillance of the instrument in use

6.1 Documentation necessary

- Annex to the EU type examination certificate,
- User manual.

6.2 Special equipment or software

The following tools for service meter programming and local data downloads are used:

- MiQen 2.1 (Iskra software)
- Optical adapter WM-USB
- Personal computer

The tool is intended for the operators who service or reprogram the meters in the laboratory or read-out the meters in the field.

6.3 Identification of software

Identification – SW version can be read from LCD or using RS485 or IR communication. The check sum (CRC) of main processor firmware and check sum of phase measuring modules are calculated and displayed during initialization and later they can be read from LCD FW identification window or MODBUS registers. If CRC for code is changed and does not correspond to the initial CRC an error is detected during startup and ERROR is shown on the LCD. CRC is checked after every restart of the meter and periodically with 1 minute period.

| Version Register: 30013 | Check sum main processor - Register: Register: 30081 (HI), 30097 (LOW) | Check sum – measuring modules Register 30087, 30088, 30089 |
|-------------------------|--|--|
| 2.05 | EEC6 6478 | B5E6 |
| 2.08 | 50C7 0A27 | B5E6 |
| 2.09 | E1E8 9018 | B5E6 |
| 2.11 | 017E C8E1 | B5E6 |
| 2.12 | F03E C99D | B5E6 |

6.4 Identification of hardware

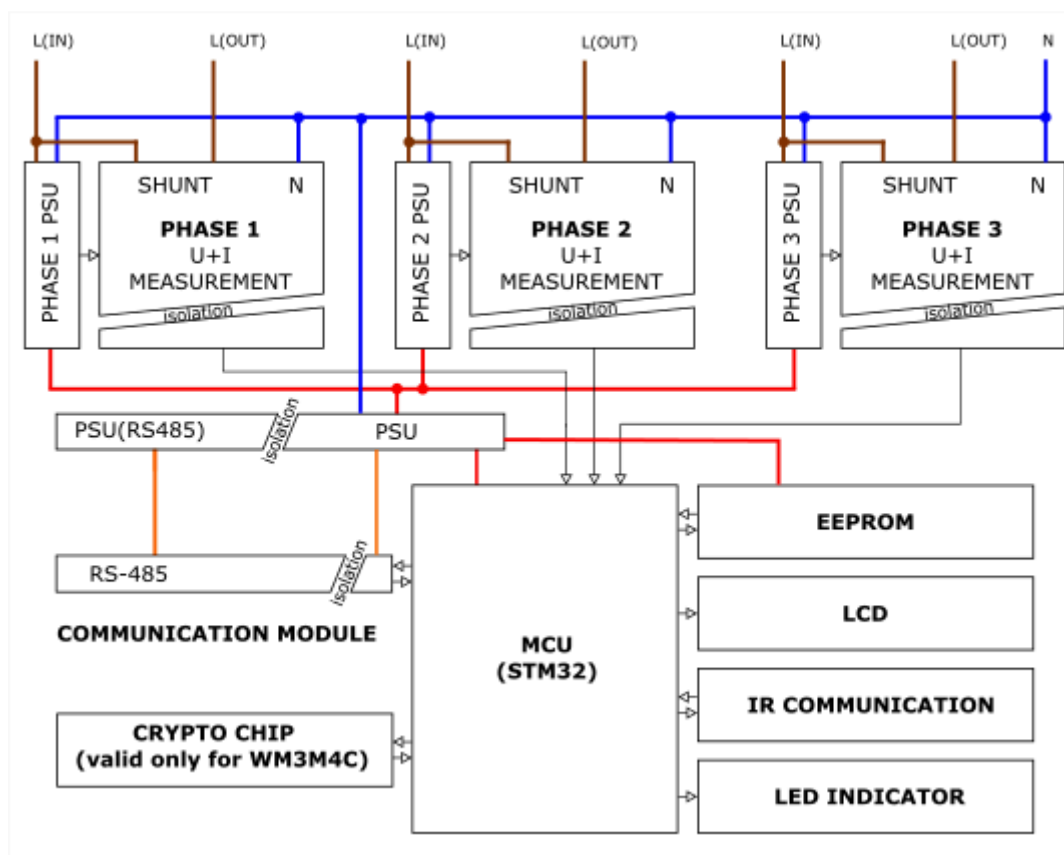

Figure 6: Block diagram of signal conversion and processing

Complete WM3M4C/WM3M4 system is assembled with three main measuring units and communication unit:

- Individual phase measurement unit,
- Power supply unit,
- Processing unit (MCU) with IR communication, LED indicator, LCD support,

- RS 485 communication module,
- EEPROM for parameter and energy register storage,
- Crypto chip for digital signatures (only for WM3M4C).

6.5 Adjustment

The meter casing is sealed. Adjustment is performed only during the production. Later adjustment during the meter life span is not expected.

7. Security measures

The meters are sealed at the following places:
The edge of the meter cover – sealing labels.

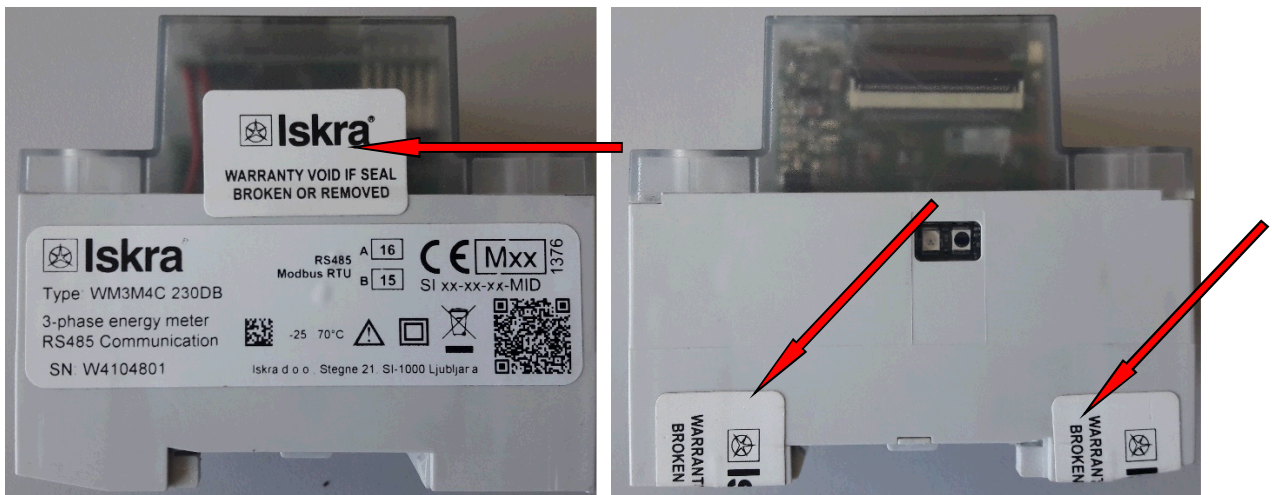

Figure 7: Location of sealing in the form of label (WM3M4C and WM3M4).

8. Markings and inscriptions

- CE marking and supplementary metrology marking
- Manufacturer's name and address
- Accuracy class
- Reference voltage
- Climatic environment
- Output constant
- Meter identification type designation
- Serial number
- Temperature range

9. Changes:

Revision 2:

- Text of Figure 2 was changed.
- In chapter 6.3 there are new values for version 2.05.

Revision 3:

- In chapter 6.3 there is a new software version 2.08 added.

Revision 4:

- In chapter 6.3 there is a new software version 2.09 added.

Revision 5:

- In chapter 6.3 there is a new software version 2.11 added.
- In chapter 2.6 new reference to file for technical documentation was added.

Revision 6:

- In chapter 6.3 there is a new software version 2.12 added.
- In chapter 2.6 new reference to file for technical documentation was added.
- Figure 1 was updated.